

BUSHING CURRENT TRANSFORMERS WITH ALUMINIUM MOUNTING ANGLES

Available in single or multi-core configuration of Metering and/or protection dimension 'c' is advised at the time of enquiry.

*Also suitable for use on H.V. Systems up to 12kV/95kV
B.I.L when used with Stemar discharge free phase bushing bar.*

Terminal Covers available as an option.

MOUNTING:

- Angle: angles for larger heavy units.

ORDERING NOMENCLATURE:

BCT TYPE/ID_RATIO_CLASS (_=SPACE)

eg. BCT1/70 400/5 10P20F10

Type	A	B	C	D	E	F	G
BCT100/150	100	150	*	70	75	40	30
BCT120	120	120	*	90	60	60	30
BCT130	130	130	*	100	65	70	30
BCT145	145	145	*	115	73	85	30
BCT160	160	160	*	130	80	100	30
BCT165 (BCT1)	165	165	*	135	83	105	30
BCT190	190	190	*	160	95	130	30
BCT200 (BCT2)	200	200	*	170	100	140	30
BCT220	220	220	*	190	110	160	30
BCT240	240	240	*	210	120	180	30
BCT270 (BCT3)	270	270	*	240	135	210	30
BCT300	300	300	*	270	150	240	30
BCT310	310	310	*	280	155	250	30
BCT360	360	360	*	330	180	300	30
BCT400	400	400	*	370	200	340	30
BCT440	440	440	*	410	220	380	30
BCT500	500	500	*	470	250	440	30

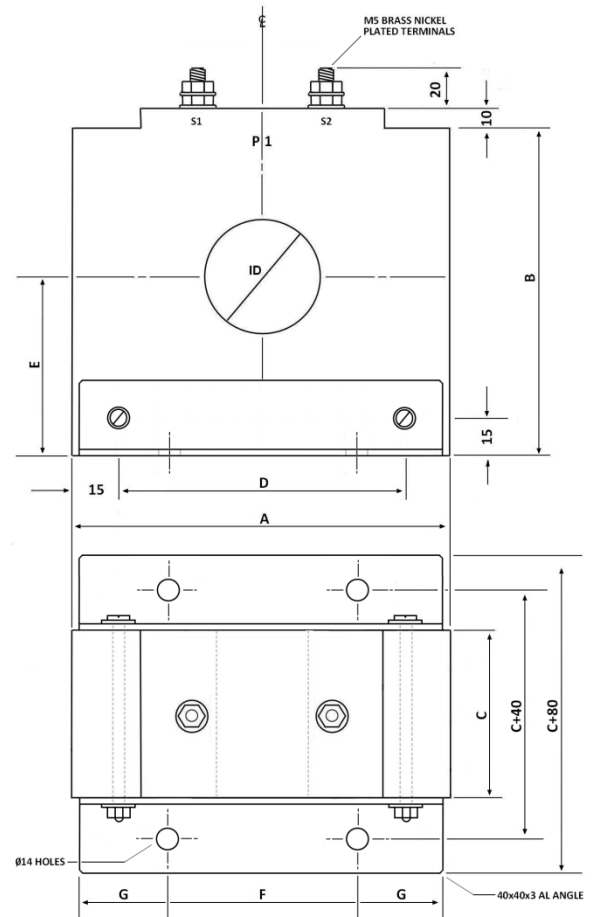

Dimension 'c' is advised at the time of enquiry.



Let your need be our challenge

Stemar Electrical Products Pty. Ltd.

Phone: +61 2 9771 2100 Fax: +61 2 9774 5585 Email: sales@stemar.com.au Web: www.stemar.com.au
243 Milperra Rd, P.O. Box 538 REVESBY, NSW 2212 Australia

